

We pioneer motion

# LASER-EQUILIGN2 shaft alignment system

Line up for higher machine availability

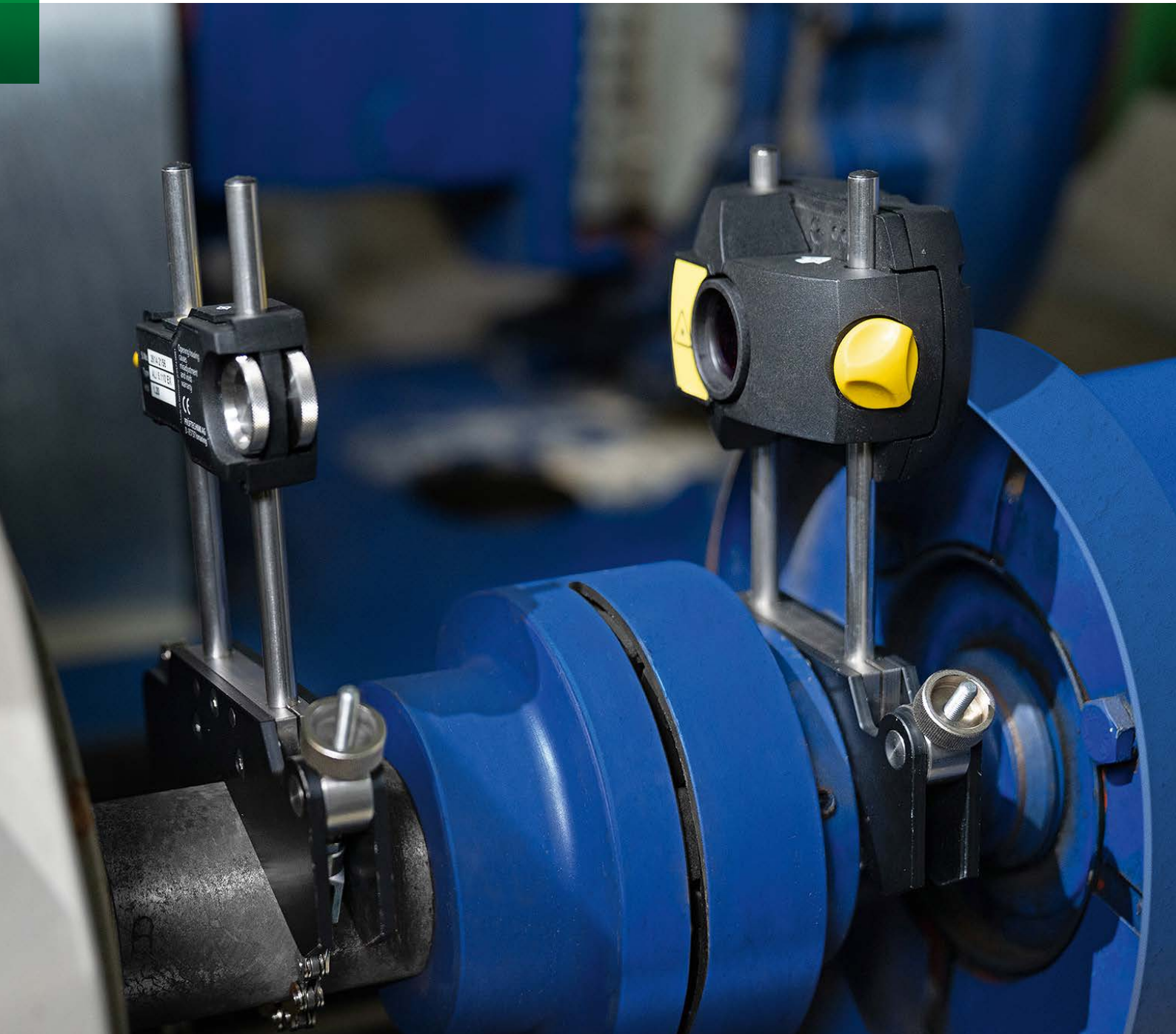

# Contents

Alignment – essential for industrial production	03
Better alignment with LASER-EQUILIGN2	04
Precision for maximum machine performance	06
Efficiency for increased cost-effectiveness	07
Convenience through ease of operation	08
Technical data	09

## Summary

The precise alignment of rotating shafts is essential for cost-effective production in every industry. It reduces energy consumption, increases machine availability, and extends the machine's lifecycles. LASER-EQUILIGN2, the new generation of laser alignment systems for horizontal applications, features maximum precision, extreme efficiency, and convenient operation. Single-laser technology enables precise measurements in any situation. LASER-EQUILIGN2 can be quickly and easily installed. The handheld tablet simplifies operation by guiding users through the alignment process step by step.



# Alignment – essential for cost-effective production

Millions of appliances around the world are connected via shafts – in every industry and for every purpose – including motors, pumps, fans, and gearboxes with roller bearings.



Horizontal motor pump application

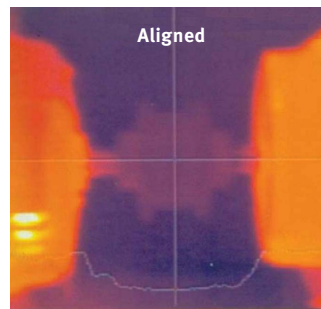
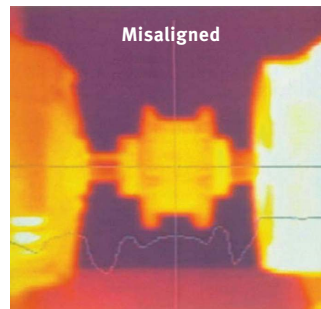

Rising temperature as a result of alignment errors

## Good arguments for precise alignment

Precise alignment optimizes machine performance, reduces maintenance expenditures, reduces wear, extends the service life of your machines, and lowers your energy costs.

Experience shows that no matter how much care is taken, alignment is seldom perfect. The consequences of even small deviations can be significant, including unwanted vibrations, a rising temperature at couplings, bearings, lubrication, motors, and other components, and higher energy consumption. Increased wear can result in defects and machine failures.

60%  
Imbalance and alignment errors

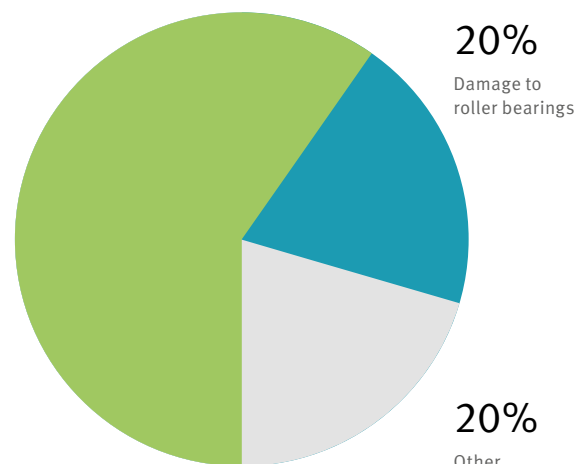

Causes of machine failure

# Better alignment with LASER-EQUILIGN2

In many cases, alignment is simply ignored. This is definitely the worst of all possible solutions. Alignment isn't a question of why, but of how.

## **Hairline gauge: imprecise**

Alignment using a hairline gauge is inexpensive and simple, but its measurements are imprecise.

## **Dial gauge: complex and cost-intensive**

Although a dial gauge is precise, its use requires a great deal of expertise and experience. The measuring process is complex and time-consuming. In addition, a dial gauge – together with the brackets and rods – requires a comparatively high investment.

## **Laser: precise and easy to use**

State-of-the-art laser technology enables precise measurements and is easy to use.

# DEVELOPMENT CONTINUES

Growing requirements for machine performance, cost-effectiveness, and speed demand solutions that offer added value. LASER-EQUILIGN2, the new generation of laser alignment systems from Schaeffler, is valued not only for its high precision and cost-effectiveness, but also for its extreme user-friendliness. The new handheld tablet offers users more convenience than has ever been available before.





# Systematic approach to precise and convenient alignment

LASER-EQUILIGN2 is a system made up of various components that are perfectly coordinated with one another. It enables precise alignment and guides users through the process step by step.

## 1 Handheld tablet

- Tells users what to do, when, and how
- Eight-inch touchscreen tablet
- Impact-resistant and watertight (IP68)
- RFID inside
- High resolution camera with flash for documentation purposes

## 2 Chargers, each with 5 adapters

## 3 Shaft brackets for laser/sensor unit and reflector

## 4 Laser/sensor

- Bluetooth communication
- Li-ion battery
- Superior single-laser/sensor technology

## 5 Reflector with roof prism

## 6 MICRO USB CABLE for charging the sensor

## 7 USB-C DATA CABLE for charging the tablet

## 8 USB A-USB C ADAPTER CABLE for data transfer

## 9 Case

## 10 Tape measure

## 11 Hex wrench, SW 4



# Precision maximizes machine performance

The superiority of the single-laser/sensor technology integrated in LASER-EQUILIGN2 has been proven in actual practice. Firstly, the fact that only one laser needs to be aligned with the reflector simplifies and speeds up installation. Secondly, the technology enables measurements that are extremely precise because the laser beam measures with twice the angle resolution, thanks to the roof prism in the reflector. This is especially beneficial in applications with short shafts where the laser and sensor are in close proximity to one another.

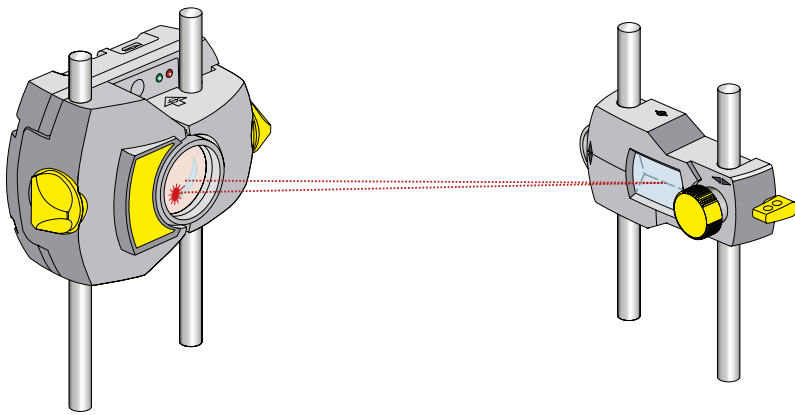

## Active clock mode with four measuring points

The more measured data collected over a larger rotation angle, the more precise the results will be. That's why LASER-EQUILIGN2 measures at four points. This allows the shaft to be optimally aligned and keeps machine performance at the required level.

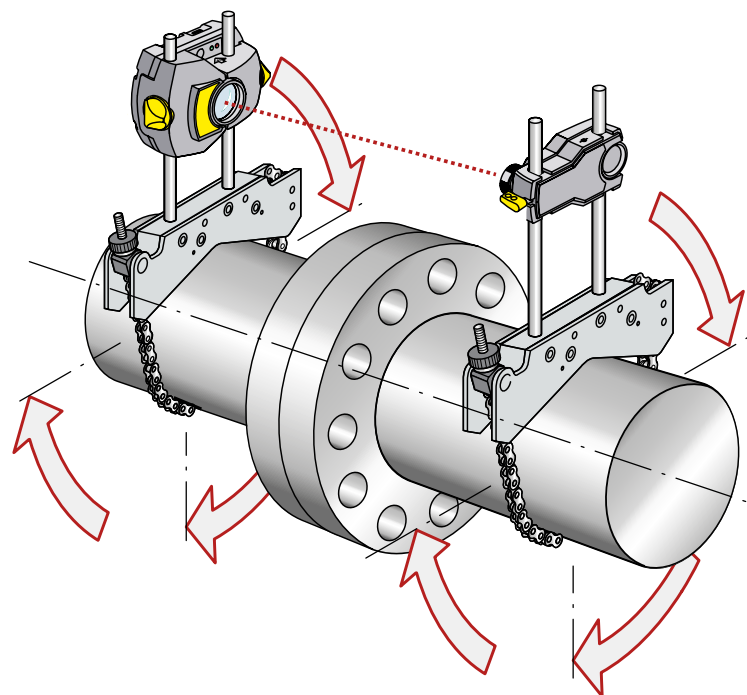
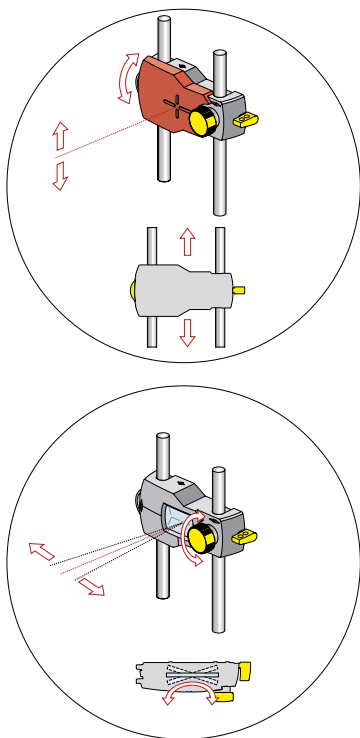

# Efficiency increases cost-effectiveness

Precise alignment using LASER-EQUILIGN2 has a critical impact on your cost-effectiveness.



It reduces your machines' power consumption



It reduces bearing and seal wear, which lowers spare parts costs



It increases machine availability



It extends your machines' lifecycle

## Reduced power consumption – a sample calculation

Even a slight reduction in the power consumed by your machines can have noticeable effects on your annual energy costs. This example shows the savings that result when the power consumption of six machines at 75 to 200 kW is reduced by 1 percent given a daily running time of eight hours.

Motor output	75kW	100kW	200kW
Annual energy costs	€37,440	€49,920	€99,840
Assumed energy reduction	1%	1%	1%
Savings per machine	€74	€499	€998
<b>Savings with six machines</b>	<b>€2,244</b>	<b>€2,994</b>	<b>€5,988</b>



## Convenience thanks to easy operation

With its large, user-friendly, handheld tablet, LASER-EQUILIGN2 is extremely convenient to operate. This is a priceless advantage in the often harsh environment of a factory hall. The eight-inch screen displays all the functions in a clear arrangement. The easy-to-understand icons enable intuitive operation with no extensive training required.

### Always the optimal result

The tablet guides users through the alignment process step by step, providing them with clear instructions on what to do, when, and how. This increases confidence and significantly improves the quality of the alignment. Live Move provides additional orientation. This innovative function monitors alignment corrections in real time based on the traffic-light principle: Red means “outside tolerance,” yellow means “within the acceptable range,” and green means “within the optimal range.”

Thanks to a Bluetooth connection and battery operation, LASER-EQUILIGN2 requires no bothersome cables, making it highly convenient in everyday use. The same goes for the RFID function, which ensures the automatic identification of machines, as well as data exchange in the local environment.



The handheld tablet provides clear instructions on how to successfully carry out the alignment process



# Technical Data



## LASER-EQUILIGN2

Case dimensions	W x H x D	Approx. 500 x 410 x 140 mm
Total weight		Approx. 7.8 kg

## LASER-EQUILIGN2-TABLET

Operating system		Kiosked Android Operation System
CPU	Processor:	Exynos 7 Octa, 1.6 GHz Octa-Core (Cortex®-A53)
	Storage:	3 GB RAM, 16 GB flash memory
Display	Technology:	TFT Integrated light meter for automatically adapting background lighting to ambient brightness in order to extend battery life
	Resolution:	1280 x 800 pixels
	Dimensions:	203.1 mm (8")
Connectivity	Wi-Fi:	802.11 a/b/g/n/ac (2.4 GHz +5 GHz)
	Wireless:	4.2
	RFID:	NFC
Camera	Resolution main camera	8.0 MP, Auto Focus
	Resolution front camera	5.0 MP
IP classification	IP68:	Dust-tight, immersible 1.5 m
Temperature range	Operating:	-20°C to 50°C (-4°F to 122°F)
Battery	Type:	Li-ion rechargeable battery 3.8 V/4450 mAh/16.91 Wh
	Operating time:	Up to 11 hours
Dimensions	W x H x D	Approx. 256 x 149 x 35 mm (10 5/64" x 5 55/64" x 1 3/8")
Weight		Approx. 710 g (1.6 lbs)

# Technical Data



## Laser/sensor unit

### LASER-EQUILIGN2.TRANS

Measuring principle	Coaxial, reflected laser beam	
LED indicators	1 LED for laser status and battery status 1 LED for wireless communication	
Power supply	Battery:	Lithium-ion rechargeable 3.7 V/5 Wh
	Operating time:	10 hours (continuous use)
	Charging time via charger:	2.5 h for up to 90% - 3.5 h for up to 100%
	Charging time via USB port:	3 h for up to 90% - 4 h for up to 100%
IP classification	IP 65:	Dust-tight, protected against water spray, impact-resistant
	Relative humidity:	10% to 90% (non-condensing)
Protection against incident light	Yes	
Temperature range	Operating:	-10°C to 50°C (14°F to 122°F)
	Charging:	0°C to 40°C (32°F to 104°F)
	Storage:	-20°C to 60°C (-4°F to 140°F)
Dimensions	W x H x D	Approx. 105 x 69 x 55 mm (4 9/64" x 2 23/32" x 2 11/64")
Weight	Type:	Approx. 210 g (7.4 oz) with dust cap
Detector	Measuring range:	Unlimited, flexibly expandable
	Resolution:	1 µm (0.04 mil) and angle 10 µRad
	Accuracy (average):	> 98%
Inclinometer	Measuring range:	0° to 360°
	Resolution:	0.1°
	Inclinometer error (Ta = 22°C):	0.3% full scale

# Technical Data



## Laser/sensor unit

### LASER-EQUILIGN2.TRANS

Laser	Type:	Semiconductor laser diode
	Wavelength:	630 - 680 nm (red, visible)
	Safety class:	Class 2 according to IEC 60825-1:2014 Laser corresponds to 21 CFR 1040.10 and 1040.11 with the exception of deviations pursuant to Laser Notice No. 50 from June 24, 2007.
	Beam power:	< 1 mW
	Beam divergence:	< 0.3 mRad
	Safety precautions:	Never look directly into the laser beam
External interface	Wireless communication	
Transmission distance	Up to 30 m (98 ft) direct line of sight	
CE conformity	See CE Declaration of Conformity	
Country-specific approvals	LASER-EQUILIGN2 096035269-0000-10 EU + Switzerland, Norway, UK USA, Australia, Singapore, Thailand, Brazil, India, Malaysia, South Africa, UAE  LASER-EQUILIGN2-CA 096866314-0000-10 Canada	

## Reflector (prism)

### LASER.REFLECT

Type	90° roof prism	
Accuracy (average)	> 99%	
IP classification	IP 67 (immersible, dust-tight)	
Temperature range	Operating:	-20°C to 60°C (-4°F to 140°F)
	Storage:	-20°C to 80°C (-4°F to 176°F)
Dimensions	W x H x D	Approx. 100 x 41 x 35 mm (4" x 1 5/8" x 1 3/8")
Weight	Approx. 65 g (2.3 oz)	

**Schaeffler Technologies AG & Co. KG**

Industriestrasse 1 – 3  
91074 Herzogenaurach  
Germany  
[www.schaeffler.de/en/shaft-alignment-device](http://www.schaeffler.de/en/shaft-alignment-device)  
[industrial-services@schaeffler.com](mailto:industrial-services@schaeffler.com)  
Tel. +49 2407 9149-66

In Germany:  
Phone 0180 5003872  
From other countries:  
Phone +49 9132 82-0

Every care has been taken to ensure the correctness of the information contained in this publication but no liability can be accepted for any errors or omissions. We reserve the right to make technical changes.



Avenida Ricardo Mella 119.  
36330 - Vigo - Pontevedra  
Teléfono: **986.21.35.35**  
Mail: [ventas@enriel.com](mailto:ventas@enriel.com)

© Schaeffler Technologies AG & Co. KG  
Issued: 2021, September  
This publication or parts thereof may not be reproduced without our permission.